

Spiro USB Service Manual

075-12
Revision 1.0 February 2004

©Micro Medical Limited, P.O. Box 6, Rochester, Kent ME1 2AZ

Spiro USB - System Overview (Fig. 1)

The Spiro USB is a PC connected spirometer dedicated to work with SPIDA 5 spirometry software.

It consists of a removable digital volume transducer (1) and a housing (2) containing a microprocessor control circuit and USB driver.

When testing a subject the transducer is inserted into the housing, which is plugged into a USB socket of a PC. The digital volume transducer is used to measure the subjects expired flow and volume in accordance with the operating manual.

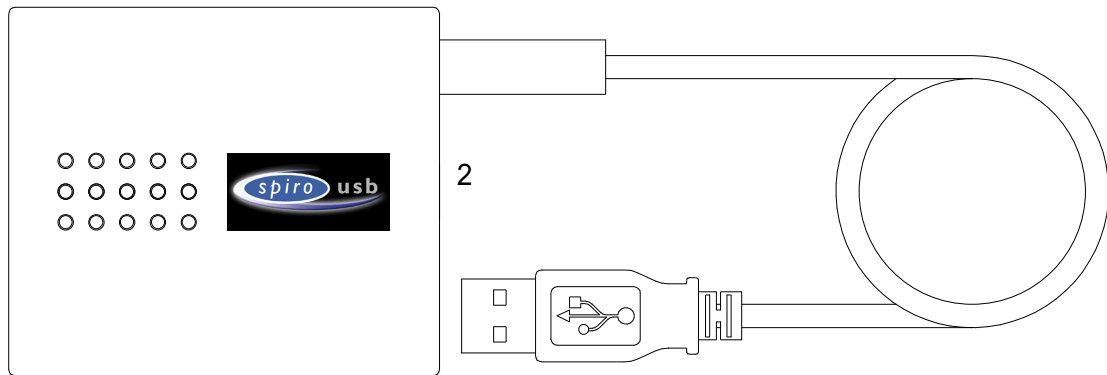
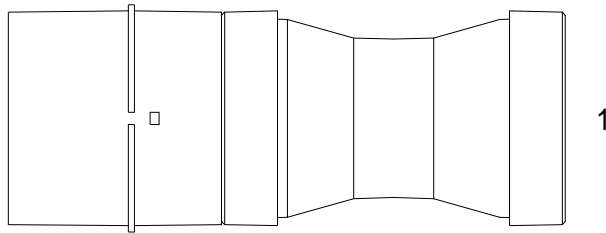

Transducer (Fig. 2)

The Micro Medical digital volume transducer consists of an acrylic tube with a vane positioned between two swirl plates. The low inertia vane is attached to a stainless steel pivot which is free to rotate on two jewelled bearings mounted at the centre of the swirl plates. As air is passed through the transducer a vortex is created by the swirl plates which causes the vane to rotate in a direction dependant upon the direction of air flow. The number of rotations is proportional to the volume of air passed through the transducer and the frequency of rotation is proportional to the flow rate. The transducer housing consists of a main body which contains a pair of light emitting diodes (LED's) and phototransistors. The transducer is fixed to the mouthpiece holder which pushes into the main body and is captured by an "O" ring seal. The LED's produce infra red beams which are interrupted by the vane twice per revolution. This interruption is sensed by the phototransistors. The output from the collector of each phototransistor will be a square wave with a phase difference between the two of + or - 90 degrees depending upon the direction of flow.

There is no routine maintenance required for the transducer other than cleaning according to the instructions in the operating manual.

Micro Medical Digital Volume Transducer

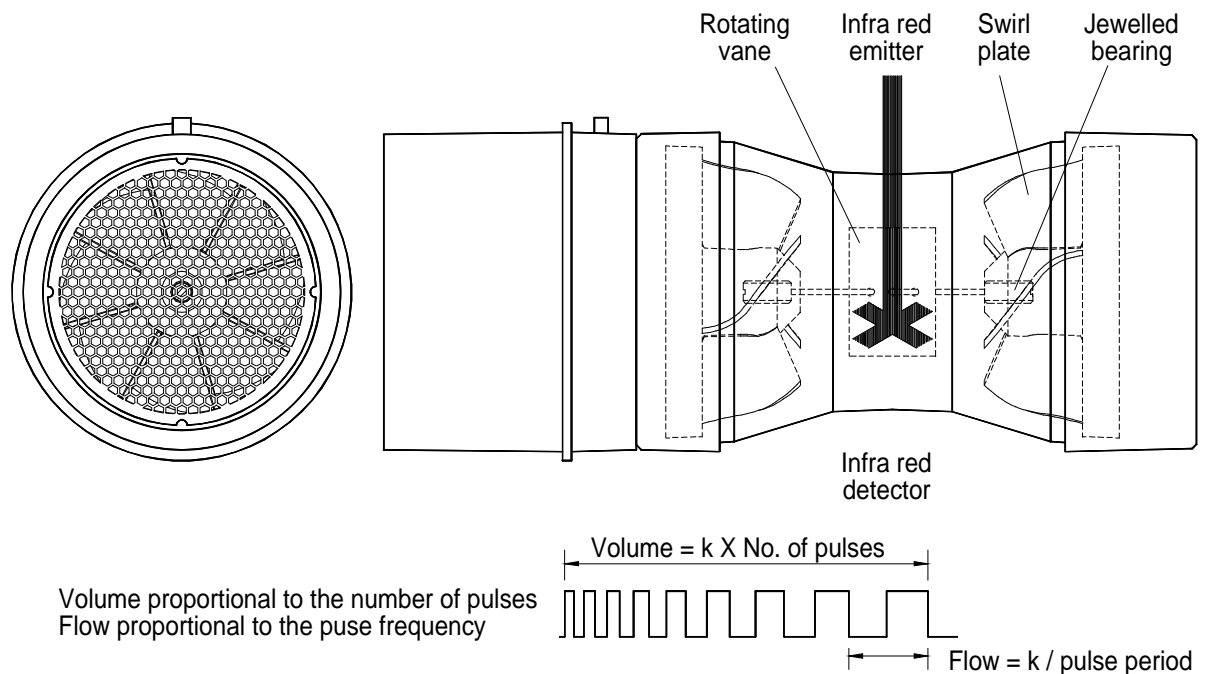

Disassembly (Fig. 3)

1. Carefully remove both Spiro USB labels from the transducer housing.
2. Remove the screw under each label.
3. Pull apart the two halves of the housing as shown below:

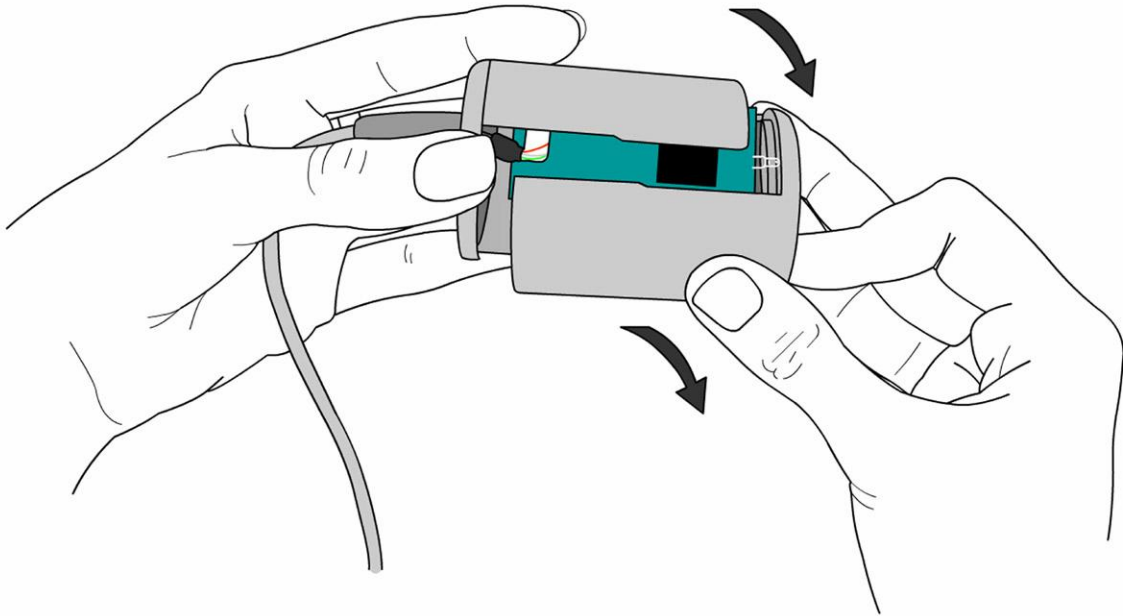

Reassembly (Fig. 4)

Please note: Do not use excessive force when reassembling.

1. Ensure the PCB is aligned correctly as shown in Fig. 4.
2. Pull the cable gland through the hole in housing A (already on the cable) and locate the centre moulding into the housing.
3. Line up the channel on the centre moulding with the screw hole of housing A.
4. When refitting housing B, locate the moulded bracket (with the nut) between the end of the channel and housing A and carefully pivot housing B around until the two housings meet (ensuring the blue LED fits into it's hole).
5. Replace the screws.
6. Carefully reposition the Spiro USB labels.

The PCB, LED'S and phototransistors will be accessible as shown below:

Fig. 4.

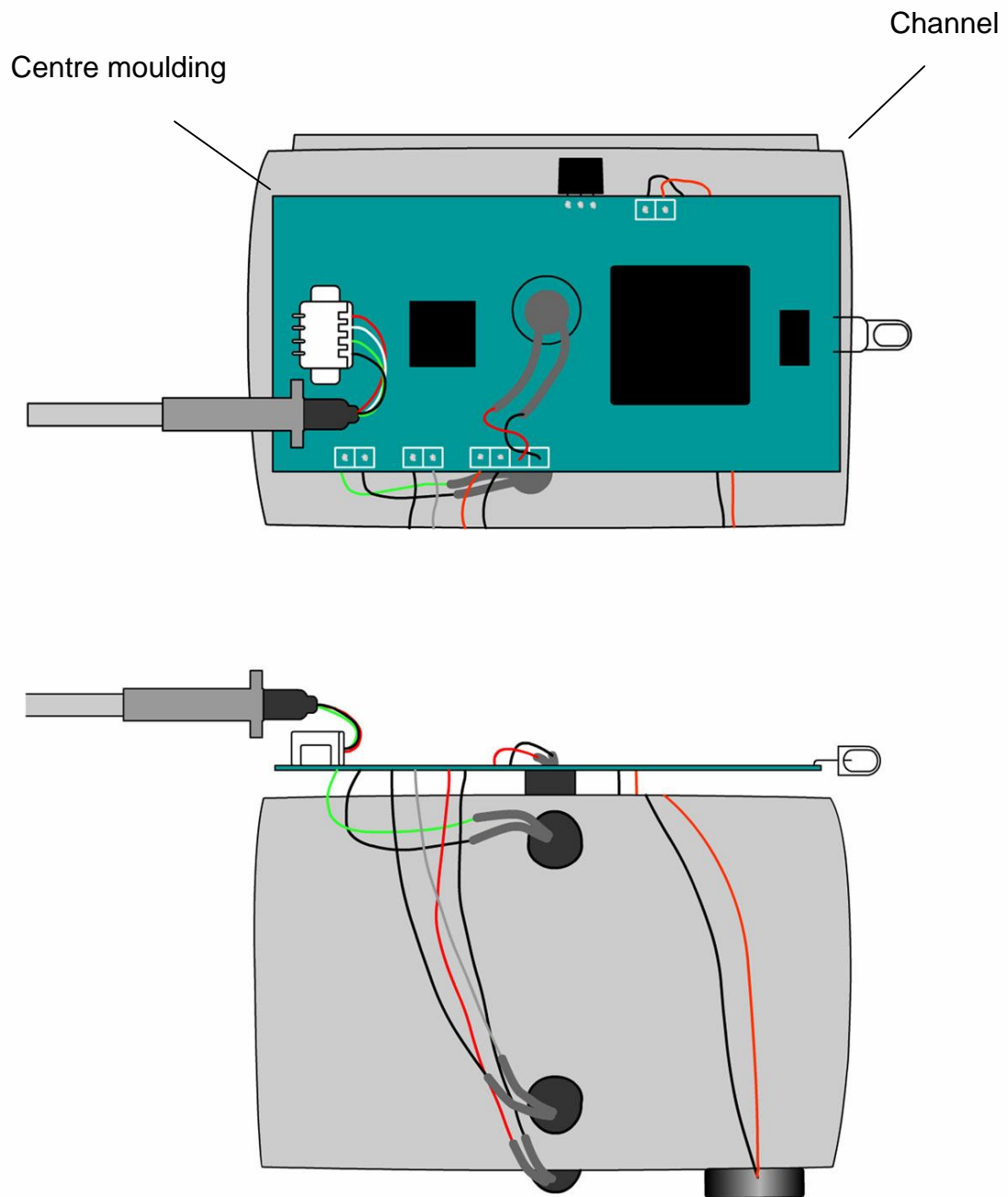

Microprocessor control circuit, see drawing 075-01 and 075-02

The microprocessor control circuit monitors the transducer pulses, carries out the spirometry routines, and communicates with the PC via a USB driver under the control of its internal program.

Power for the processor circuit is derived from the 5 volt USB power line. The power line is filtered by C12, L1 and C13. The filtered 5 volt is regulated down to 3.3 volts by the linear regulator, U7. U7 also provides a reset signal for the microprocessor.

The microprocessor, U3, is a Hitachi HD64F2318 16 bit microprocessor with 256K of flash memory and 8K of Ram. The system clock is supplied by 12MHz crystal, X1. There is also 512 Kbytes of external RAM, U8, used for storing pulses during a spirometry manoeuvre. The internal flash memory is used to store the microprocessor firmware.

Calibration data and system data is stored in an EEPROM, U2. Communication to the EEPROM is carried out using a two wire serial connection to pins 54 and 55 of the microprocessor. If the device is ever replaced, the unit will have to undergo factory recalibration.

Ambient temperature is monitored by a solid-state temperature sensor, U9. It communicates with the microprocessor via a one wire serial interface on pin 90. The ambient temperature reading is used for adjusting inspiratory volume at ambient temperature to volume at body temperature.

The supply to the two series LED's, mounted inside the transducer housing, is provided through TR1, which is switched on by pin 4 of the microprocessor during a spirometry manoeuvre. Inside the transducer housing the two phototransistors used to detect the interrupted infra-red beam are in open collector configuration. The pull up resistor for the two phototransistors is provided by R7 and R8. Pulses from the phototransistor, TR2, are applied to the pulse timing input of the processor, pin 5, after being squared up by the action of the Schmitt inverter, U4. Pulses from the second phototransistor, TR3, after conditionings, U5, are applied to pin 6 of the microprocessor and are used to determine the direction of flow. The pulse count is used to determine the volume passed through the transducer since the start of the test and the pulse period is used to determine the flow at each volume increment.

The microprocessor communicates with the host PC via a USB interface, U6. U6 is connected to the microprocessor data bus and one address line, A0.

The 512k x 8 static RAM, U8, is located on the underside of the PCB and communicates with the processor on the 19-bit address bus and 8-bit data bus.

The speaker, J1, is directly connected to ports on pins 91 and 92 that are toggled at 1 KHz to generate the sound.

Drawing No.	075-00	Date 07/01/04
Revision No. 1.4		Page: 1 OF 3
Designation	Part No.	Description.
U1	BU4S11	Individual CMOS Schmitt NAND gate
U2	24LC00-OT	128 bit serial EEPROM
U3	HD64F2318VTE25	Hitachi microcontroller
U4	BU4S584	Individual CMOS Schmitt inverter
U5	BU4S584	Individual CMOS Schmitt inverter
U6	SL811HST	USB interface
U7	MAX6349TL	3V3 regulator with integrated RESET
U8	K6X4008T1F-VF70	512k X 8 bit CMOS static RAM,
U9	DS18S20	Digital thermometer
TR1	DTD113EK	NPN digital transistor
R1		100K resistor 1%
R2		100K resistor 1%
R3		180 Ohm resistor 1%
R4		10K resistor 1%
R5		10K resistor 1%
R6		1K resistor 1%
R7		4.7K resistor 1%
R8		4.7K resistor 1%
R9		22 Ohm resistor 1%
R10		22 Ohm resistor 1%
R11		1.5K resistor 1%
R12		120 Ohm resistor 1%
R13		100K resistor 1%
C1		33pF ceramic capacitor
C2		33pF ceramic capacitor
C3		100nF ceramic capacitor
C4		100nF ceramic capacitor
C5		100nF ceramic capacitor
C6		100nF ceramic capacitor
C7		1nF ceramic capacitor
C8		1nF ceramic capacitor
C9		100nF ceramic capacitor
C10		100nF ceramic capacitor
C11		4.7uF ceramic capacitor
C12		100nF ceramic capacitor
C13		1uF ceramic capacitor
L1	LQW18ANR22G00D	220nH inductor
X1		12MHz crystal
LED	L934MBC	Blue LED
LED2	SEP8705	Infra red LED
LED3	SEP8705	Infra red LED
TR2	SDP8405	Infra red photo transistor
TR3	SDP8405	Infra red photo transistor

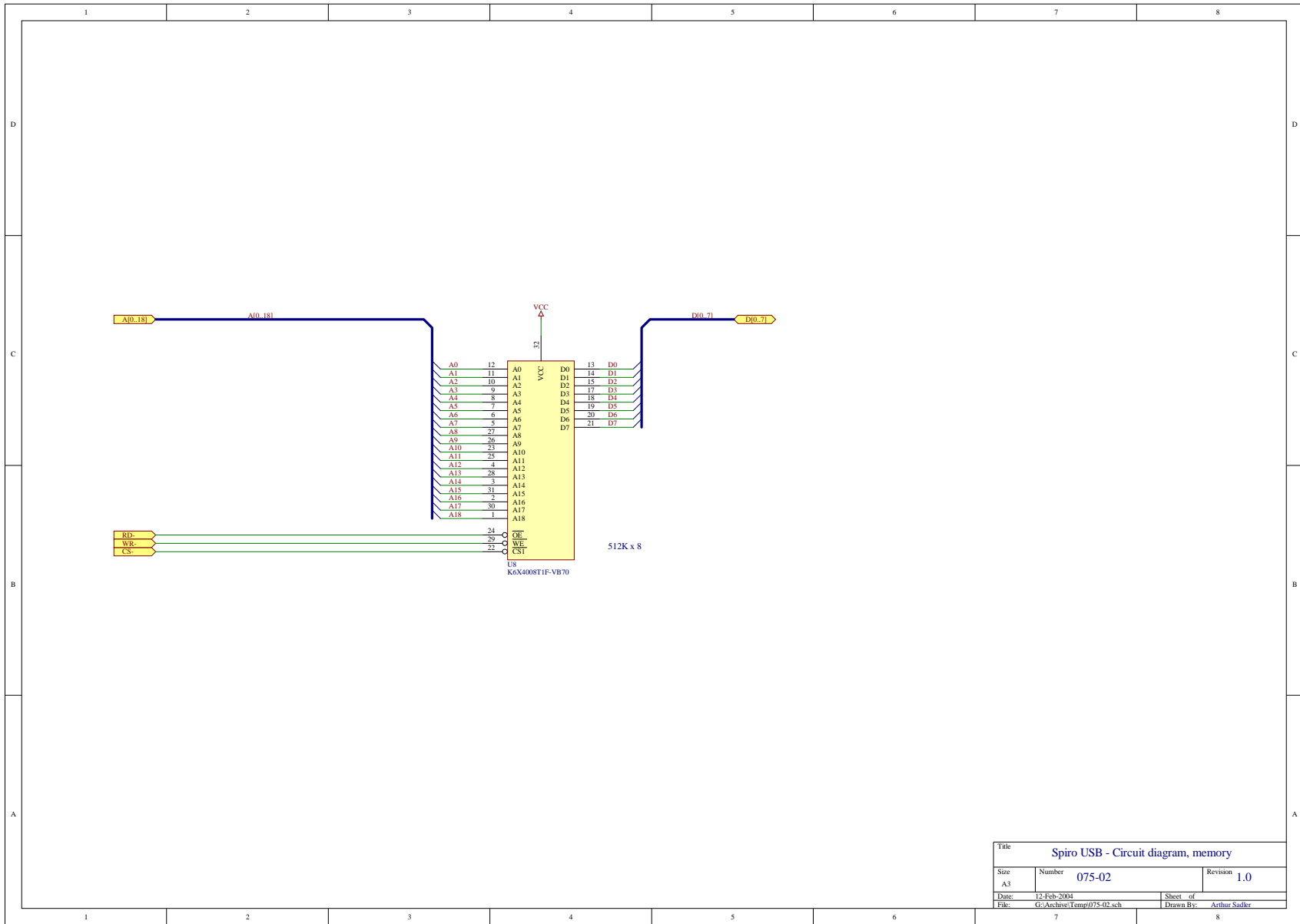

Title			Spiro USB - Circuit diagram, memory		
Size	Number	Revision			
A3	075-02	1.0			
Date:	12-Feb-2004	Sheet	of		
File:	G:\Archive\Temp\075-02.sch	Drawn By:	Arthur Sadler		